



On-site Machine Tools

CATALOG 2025



The Power of our excellence: **Over 30 years of experience**

MAUCOTOOLS began its journey with a clear focus: specializing in a single product line – Multifunctional Portable Boring Machines for on-site line boring and bore welding operations.

Our extensive experience and deep understanding of the needs and challenges faced by our customers have led to the development of the next generation of On-Site Portable Boring Machines, the DUAL SYSTEM Series.

The Portable Boring Machines by MAUCOTOOLS are engineered with our exclusive, patented DUAL SYSTEM. This groundbreaking innovation has transformed portable machine tools into truly modular systems, designed with two separate modules capable of performing independent operations. The DUAL SYSTEM also provides our customers with the unique ability to work efficiently in confined spaces.

With a renewed management team and a fresh philosophy, company culture, vision, and redesigned product lines, MAUCOTOOLS has expanded to deliver cutting-edge on-site solutions across multiple industries, including: Earthmoving and Construction, Mining, Oil & Gas, Shipbuilding and Repairs, Power Generation.

Our on-site solutions are manufactured to meet international standards, fully compliant with ISO 9001:2015. Additionally, all MAUCOTOOLS products are certified to meet CE specifications of the European Union.

At the heart of MAUCOTOOLS is our people. Our global team and extensive worldwide network ensure that we are always close to our customers, offering unparalleled professionalism, anytime and anywhere.



Dasa-Rägister



MADE IN ITALY

Vision

To revolutionize the world of Maintenance, Repair, and Operations (MRO) by accelerating the shift towards efficient, fast, and intelligent ways of working.

Mission

To design and deliver innovative on-site solutions worldwide that are Portable, Modular, User-Friendly, and Time-Saving, tailored for diverse industries such as earthmoving, marine, offshore and onshore, mining, and piping.

To build a global team and a worldwide network that supports customer growth and satisfaction, fostering long-term partnerships and excellence in service.

To create an inspiring work environment that motivates and empowers our people to achieve their fullest potential.





L3M400
DUAL SYSTEM

MALCO TOOLS

DUAL SYSTEM

L3M400
DUAL SYSTEM

DUAL SYSTEM

THAL





MAUCOTOOLS PATENTED DUAL SYSTEM

The MAUCOTOOLS DUAL SYSTEM is a groundbreaking solution for on-site machining, designed with **patented modularity**. It features two lightweight modules, each weighing 17kg, allowing for **easy transport and operation without heavy lifting equipment**.

Both the **Rotation and Feed Modules** have independent control panels, enabling **simultaneous machining tasks** like facing and welding. This system offers unparalleled efficiency, precision, and safety, with built-in protection systems for motor and error prevention, making it ideal for professionals handling complex projects in the field.

KEY FEATURES & ADVANTAGES

Truly Portable Design: Unlike conventional “portable” machines that are merely transportable, the MAUCOTOOLS DUAL SYSTEM divides its weight between two modules, each weighing approximately 17kg. This makes the machine genuinely portable and manageable by a single operator without the need for lifting tools.

Modular construction: The DUAL SYSTEM is composed of two separate modules:

Rotation Module: Responsible for the rotational motion during operations like line boring and facing.

Feed Module: Generates feed motion, essential for precision tasks like overlay welding.

Simultaneous Dual Operation: Thanks to independent control panels, the Rotation and Feed Modules can be operated concurrently, enabling simultaneous machining tasks—such as performing a facing operation on one workpiece while executing overlay welding on another.

Anti-Vibration Robustness: Both modules, whether used together or separately, ensure structural stability, minimizing vibrations and maintaining high precision during all machining tasks.

DUAL SYSTEM Feed Module



DUAL SYSTEM Rotation Module



MAUCOTOOLS S.R.L

Località Serramonda | Z.I. | 88044 | Marcellinara (CZ) | Italy
+39 0961 021836 | maucotools@maucotools.com



PORTABLE LINE BORING MACHINE

LBM DUAL SYSTEM

The LBM DUAL SYSTEM series is designed to meet a wide range of on-site machining needs, combining precision and portability. Each model offers unique capabilities, from Line Boring and Bore Welding to Facing and tapping, covering diameters from Ø22mm to Ø600mm.

Whether you choose the compact LBM250, the versatile LBM400, or the heavy-duty LBM600X, all models share the same innovative DUAL SYSTEM. With lightweight modules for easy handling and high rigidity for accurate machining, the LBM DUAL SYSTEM series ensures exceptional performance across industrial applications.



LBM250 DUAL SYSTEM

Boring Bar	20mm - 40mm (0.78' - 1.57')
Internal line boring	22mm - 250mm (0.88' - 9.84')
Internal Automatic Bore Welding	32mm - 250mm (1.28' - 9.84')
External Automatic Bore Welding	22mm - 250mm (0.88' - 9.84')
Drilling	10mm - 45mm (0.39' - 1.77')
Tapping	10mm - 45mm (0.39' - 1.77')
Flange Facing and Seeger Circlips	Optional with FK (Facing Kit)
External Turning	Optional with KTE (Surfacing Kit)



LBM400 DUAL SYSTEM

Boring Bar	40mm (1.57')
Internal line boring	42mm - 400mm (1.65' - 15.75')
Internal Automatic Bore Welding	32mm - 400mm (1.28' - 15.75')
External Automatic Bore Welding	22mm - 400mm (0.88' - 15.75')
Drilling	10mm - 45mm (0.39' - 1.77')
Tapping	10mm - 45mm (0.39' - 1.77')
Flange Facing and Seeger Circlips	Optional with FK (Facing Kit)
External Turning	Optional with KTE (Surfacing Kit)



LBM600 DUAL SYSTEM

Boring Bar	40mm - 60mm (1.57' - 2.36')
Internal line boring	42mm - 600mm (1.65' - 23.62')
Internal Automatic Bore Welding	32mm - 600mm (1.28' - 23.62')
External Automatic Bore Welding	22mm - 600mm (0.88' - 23.62')
Drilling	10mm - 45mm (0.39' - 1.77')
Tapping	10mm - 45mm (0.39' - 1.77')
Flange Facing and Seeger Circlips	Optional with FK (Facing Kit)
External Turning	Optional with KTE (Surfacing Kit)



LBM600X DUAL SYSTEM

Boring Bar	60mm (2.36')
Internal line boring	62mm - 600mm (2.44' - 23.62')
Internal Automatic Bore Welding	32mm - 600mm (1.28' - 23.62')
External Automatic Bore Welding	22mm - 600mm (0.88' - 23.62')
Drilling	10mm - 45mm (0.39' - 1.77')
Tapping	10mm - 45mm (0.39' - 1.77')
Flange Facing and Seeger Circlips	Optional with FK (Facing Kit)
External Turning	Optional with KTE (Surfacing Kit)

MAUCOTOOLS S.R.L

Località Serramonda | Z.I. | 88044 | Marcellinara (CZ) |
Italy +39 0961 021836 | maucotools@maucotools.com

PORTABLE LINE BORING MACHINE OB DUAL SYSTEM



OB200 DUAL SYSTEM

Boring Bar	20mm - 40mm (0.78' - 1.57')
Internal line boring	22mm - 200mm (0.88' - 7.87')
Internal Automatic Bore Welding	Optional Welding Kit
External Automatic Bore Welding	Optional Welding Kit
Drilling	Optional
Tapping	Optional
Flange Facing and Seeger Circlips	Optional with FK (Facing Kit)
External Turning	Optional with KTE (Surfacing Kit)



OB400 DUAL SYSTEM

Boring Bar	40mm (1.57')
Internal line boring	42mm - 400mm (1.65' - 15.75')
Internal Automatic Bore Welding	Optional Welding Kit
External Automatic Bore Welding	Optional Welding Kit
Drilling	Optional
Tapping	Optional
Flange Facing and Seeger Circlips	Optional with FK (Facing Kit)
External Turning	Optional with KTE (Surfacing Kit)

PORTABLE LINE BORING MACHINE START DUAL SYSTEM



START160 DUAL SYSTEM

Boring Bar	20mm - 40mm (0.78' - 1.57')
Internal line boring	22mm - 160mm (0.88' - 6.30')
Internal Automatic Bore Welding	Optional Welding Kit
External Automatic Bore Welding	Optional Welding Kit
Drilling	Optional
Tapping	Optional
Flange Facing and Seeger Circlips	Optional with FK (Facing Kit)
External Turning	Optional with KTE (Surfacing Kit)



START400 DUAL SYSTEM

Boring Bar	40mm (1.57')
Internal line boring	42mm - 400mm (1.65' - 15.75')
Internal Automatic Bore Welding	Optional Welding Kit
External Automatic Bore Welding	Optional Welding Kit
Drilling	Optional
Tapping	Optional
Flange Facing and Seeger Circlips	Optional with FK (Facing Kit)
External Turning	Optional with KTE (Surfacing Kit)

MAUCOTOOLS S.R.L

Località Serramonda | Z.I. | 88044 | Marcellinara (CZ) |
Italy +39 0961 021836 | maucotools@maucotools.com



LEM
DUAL SYSTEM

LEM 250
DUAL SYSTEM

DUAL SYS

EMERGENCY STOP

ATTENTION
DANGER

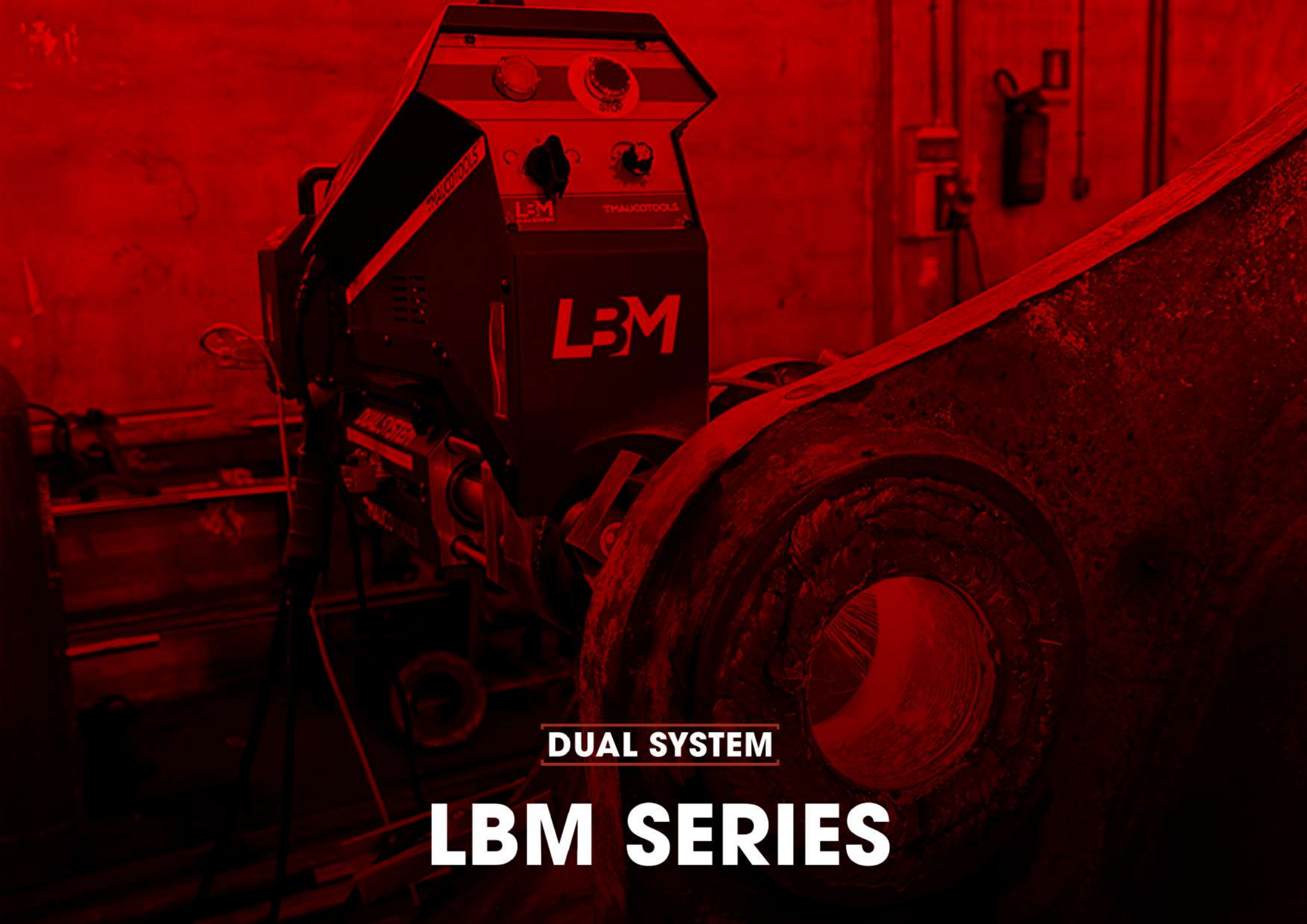

DUAL SYSTEM

LBM SERIES



PORTABLE LINE BORING MACHINE LBM250 DUAL SYSTEM

WORKING AND OPERATING RANGES

Boring Bar	Ø	20mm - 40mm (0.78' - 1.57')
Internal line boring	Ø	22mm - 250mm (0.88' - 9.84')
Internal Automatic Bore Welding	Ø	32mm - 250mm (1.28' - 9.84')
External Automatic Bore Welding	Ø	22mm - 250mm (0.88' - 9.84')
Drilling	Ø	10mm - 45mm (0.39' - 1.77')
Tapping	Ø	10mm - 45mm (0.39' - 1.77')
Flange Facing and Seeger Circlips	Ø	Optional with FK (Facing Kit)
External Turning	Ø	Optional with KTE (Surfacing Kit)

ADVANTAGES

Patented DUAL SYSTEM: Two modules for independent task (welding and facing)

Double motorization: Total control of rotation and feed

Motor protection (MMPS): MAUCOTOOLS Motor Protection System (MMPS)

Modular system: Compatible with all Optional Kits to increase machining diameter up to 600mm

Cost-effective: No need to purchase a new machine, optimizing your investment

Time and money savings: One setups, quick centering kit with magnetic system

Robust and precise: Ø16mm tool holder, connecting tool holder bars (Ø20, Ø40mm and Ø60mm)

Safety: MAUCOTOOLS Error Detection System (MeDS) and MMPS

Advanced features: Synchronized rotation and feed, unlimited longitudinal stroke, fast electronic feed

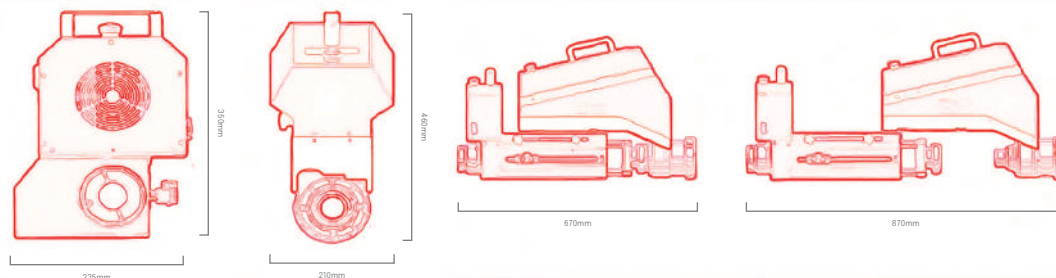

DUAL SYSTEM Feed Module

Brushless motor	YES
Phases	1
Motor type	DC
Power	125W
Speed	0-300 RPM
Feed	Electromechanical (Automatic and Manual)
MeDS	YES
MMPS	YES

DUAL SYSTEM Rotation Module

2 types of motors	Electric with 2 speeds	Hydraulic
Speed	Speed I: 54-126 RPM Speed II: 180-423 RPM	Min. 9 RPM Max. 423 RPM
Power	1800W - 220V-230V (110V Available)	5.5kW

MAUCOTOOLS S.R.L

Località Serramonda | Z.I. | 88044 | Marcellinara (CZ) |
Italy +39 0961 021836 | maucotools@maucotools.com

STANDARD PACK

LBM250 DUAL SYSTEM



x1	 cod. RT DUAL SYSTEM Rotation Module	x1	 cod. AV DUAL SYSTEM Feed Module	x1	 cod. CAV Control Panel for Feed Module	x1	 cod. CAV1 Connection cable for Feed Module	x2	 cod. C37 Power supply cable	x1	 cod. B20M Boring bar ø20mm (0.79") L=1000mm (39.79")	x1	 cod. IB20 Boring bar reduction bushing ø40mm - ø20mm	x3	 cod. KBC20 Reduction bushing for Centering Kit
x1	 cod. BRS Reduction bushing for Universal Supports	x1	 cod. PP4 Toolholder ø8mm (0.31")	x2	 cod. B27 Boring bar ø40mm (1.57") L=1000mm (39.37")	x2	 cod. B27G Internal Boring bar Coupling	x1	 cod. ECM Morse Taper Ejecting Drift	x1	 cod. CM1 Morse Cone Adapter for drilling	x1	 cod. B16 MAUCOTOOLS Locking System (MLS)	x1	 cod. A32 Bearing Carrier for Feed Module
x4	 cod. S34 Universal Support	x1	 cod. C10 Special Wrench for Universal Support	x12	 cod. S34S-60 Bracket with Spacer for Support L=60mm (2.36")	x12	 cod. SS100 Bracket for Universal support L=100mm (3.94")	x2	 cod. SM30 Magnetic Fast-Centering kit	x1	 cod. C29 Special Caliper for Internal Diameter Measurement	x1	 cod. C31M Dial Gauge with Magnetic Holder	x1	 cod. P14A Toolholder ø16mm (0.63") L=40mm (1.57")
x1	 cod. P14B Toolholder ø16mm (0.63") L=60mm (2.36")	x1	 cod. P14C Toolholder ø16mm (0.63") L=100mm (3.94")	x10	 cod. P15 Carbide Insert for Toolholder	x10	 cod. P15A Torx Screw for Toolholder	x1	 cod. PC14 Torx Wrench for Toolholder	x1	 cod. GR4 Cutting Depth Adjustment Hook	x1	 cod. PC15 Toolholder Extension ø90mm (3.54")	x1	 cod. PUC250 Toolholder Extension L=140mm (5.51")
x1	 cod. T17 Telescopic Welding Torch Shaft L=1700mm EUR Cable	x1	 cod. R17AS Front Articulated Joint for Welding Torch Shaft	x1	 cod. R17 Torch Head for Internal Welding	x1	 cod. R17AR Adaptor for R17	x1	 cod. R17P40 Torch Head Extension L=40mm (1.57")	x1	 cod. R17P60 Torch Head Extension L=60mm (2.36")	x1	 cod. R17PS External Torch Head Extension L=320mm (12.59")	x3	 cod. G08C Short Welding Wire Tip ø0,8mm (0.031")
x3	 cod. G08L Long Welding Wire Tip ø0,8mm (0.031")	x3	 cod. G10C Long Welding Wire Tip ø1,0mm (0.039")	x3	 cod. G10L Long Welding Wire Tip ø1,0mm (0.039")	x2	 cod. G22C Short Gas Nozzle	x2	 cod. G22L Long Gas Nozzle	x1	 cod. C11 Complete Kit of Service Keys and Wrenches	x1	 cod. C11 Red Metal Box (Packing)		

MAUCOTOOLS S.R.L

Località Serramonda | Z.I. | 88044 | Marcellinara (CZ) |
Italy +39 0961 021836 | maucotools@maucotools.com



PORTABLE LINE BORING MACHINE LBM400 DUAL SYSTEM

WORKING AND OPERATING RANGES

Boring Bar	Ø	40mm (1.57')
Internal line boring	Ø	42mm - 400mm (1.65' - 15.75')
Internal Automatic Bore Welding	Ø	32mm - 400mm (1.28' - 15.75')
External Automatic Bore Welding	Ø	22mm - 250mm (0.88' - 9.84')
Drilling	Ø	10mm - 45mm (0.39' - 1.77')
Tapping	Ø	10mm - 45mm (0.39' - 1.77')
Flange Facing and Seeger Circlips	Ø	Optional with FK (Facing Kit)
External Turning	Ø	Optional with KTE (Surfacing Kit)

ADVANTAGES

- Patented DUAL SYSTEM:** Two modules for independent task (welding and facing)
- Double motorization:** Total control of rotation and feed
- Motor protection (MMPS):** MAUCOTOOLS Motor Protection System (MMPS)
- Modular system:** Compatible with all Optional Kits to increase machining diameter up to 600mm
- Cost-effective:** No need to purchase a new machine, optimizing your investment
- Time and money savings:** One setups, quick centering kit with magnetic system
- Robust and precise:** Ø16mm tool holder, connecting tool holder bars (Ø20, Ø40mm and Ø60mm)
- Safety:** MAUCOTOOLS Error Detection System (MeDS) and MMPS
- Advanced features:** Synchronized rotation and feed, unlimited longitudinal stroke, fast electronic feed

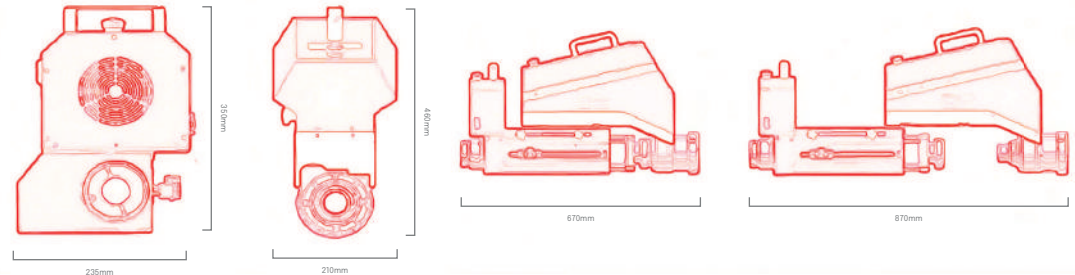

DUAL SYSTEM Feed Module

Brushless motor	YES
Phases	1
Motor type	DC
Power	125W
Speed	0-300 RPM
Feed	Electromechanical (Automatic and Manual)
MeDS	YES
MMPS	YES

DUAL SYSTEM Rotation Module

2 types of motors	Electric with 2 speeds	Hydraulic
Speed	Speed I: 54-126 RPM Speed II: 180-423 RPM	Min. 9 RPM Max. 423 RPM
Power	1800W - 220V-230V (110V Available)	5.5kW

MAUCOTOOLS S.R.L

Località Serramonda | Z.I. | 88044 | Marcellinara (CZ) | Italy
+39 0961 021836 | maucotools@maucotools.com

STANDARD PACK

LBM400 DUAL SYSTEM



- | | | | | | | | |
|------------------------------------------------------------------------------------------------------------------------------------------------------------------------------|------------------------------------------------------------------------------------------------------------------------------------------------------------------------------|-----------------------------------------------------------------------------------------------------------------------------------------------------------------|---------------------------------------------------------------------------------------------------------------------------------------------------------------------|-----------------------------------------------------------------------------------------------------------------------------------------------------------------------|----------------------------------------------------------------------------------------------------------------------------------------------------------------------------------|-------------------------------------------------------------------------------------------------------------------------------------------------------------------------------|-------------------------------------------------------------------------------------------------------------------------------------------------------------------------------|
| x1

cod. RT
DUAL SYSTEM
Rotation Module | x1

cod. AV
DUAL SYSTEM
Feed Module | x1

cod. CAV
Control Panel for
Feed Module | x1

cod. CAV1
Connection cable
for Feed Module | x2

cod. C37
Power supply
cable | x2

cod. B27
Boring bar ø40mm
(1.57') L=1000mm
(39.37') | x2

cod. B27G
Internal Boring bar
Coupling | x1

cod. ECM
Morse Taper
Ejecting Drift |
| x1

cod. CM1
Morse Cone
Adapter for drilling | x1

cod. B16
MAUCOTOOLS
Locking System
(MLS) | x1

cod. A32
Bearing Carrier for
Feed Module | x4

cod. S34
Universal
Support | x1

cod. C10
Special Wrench
for Universal
Support | x12

cod. S34S-60
Bracket with
Spacer for Support
L=60mm (2.36') | x12

cod. SS100
Bracket for
Universal support
L=100mm (3.94') | x12

cod. SS180
Bracket for
Universal support
L=180mm (7.08') |
| x2

cod. SM30
Magnetic
Fast-Centering kit | x1

cod. C29
Special Caliper for
Internal Diameter
Measurement | x1

cod. C31M
Dial Gauge with
Magnetic Holder | x1

cod. P14A
Toolholder ø16mm
(0.63') L=40mm
(1.57') | x1

cod. P14B
Toolholder ø16mm
(0.63') L=60mm
(2.36') | x1

cod. P14C
Toolholder ø16mm
(0.63') L=100mm
(3.94') | x10

cod. P15
Carbide Insert for
Toolholder | x10

cod. P15A
Torx Screw for
Toolholder |
| x1

cod. PC14
Torx Wrench for
Toolholder | x1

cod. GR4
Cutting Depth
Adjustment Hook | x1

cod. PC15
Toolholder
Extension ø90mm
(3.54') | x1

cod. PUC250
Toolholder
Extension L=140mm
(5.51') | x1

cod. PUL400
Toolholder
Extension L=320mm
(12.59') | | | |
| x1

cod. T17
Telescopic Welding
Torch Shaft
L=1700mm EUR Cable | x1

cod. R17AS
Front Articulated
Joint for Welding
Torch Shaft | x1

cod. R17
Torch Head for
Internal Welding | x1

cod. R17AR
Adaptor for R17 | x1

cod. R17P40
Torch Head
Extension
L=40mm (1.57') | x1

cod. R17P60
Torch Head
Extension
L=60mm (2.36') | x1

cod. R17P100
Torch Head
Extension
L=100mm (3.94') | x1

cod. R17PS
External Torch
Head Extension
L=320mm (12.59') |
| x3

cod. G08C
Short Welding Wire
Tip ø0.8mm (0.031') | x3

cod. G08L
Long Welding Wire
Tip ø0.8mm (0.031') | x3

cod. G10C
Long Welding Wire
Tip ø1.0mm (0.039') | x3

cod. G10L
Long Welding Wire
Tip ø1.0mm (0.039') | x2

cod. G22C
Short Gas
Nozzle | x2

cod. G22L
Long Gas
Nozzle | x1

cod. C11
Complete Kit of
Service Keys and
Wrenches | x1

cod. C11
Red Metal Box
(Packing) |

MAUCOTOOLS S.R.L

Località Serramonda | Z.I. | 88044 | Marcellinara (CZ) |
Italy +39 0961 021836 | maucotools@maucotools.com



PORTABLE LINE BORING MACHINE LBM600 DUAL SYSTEM

WORKING AND OPERATING RANGES

Boring Bar	Ø	40mm - 60mm (1.57' - 2.36")
Internal line boring	Ø	42mm - 600mm (1.65' - 23.65')
Internal Automatic Bore Welding	Ø	32mm - 600mm (1.65' - 23.65')
External Automatic Bore Welding	Ø	22mm - 250mm (0.88' - 9.84')
Drilling	Ø	10mm - 45mm (0.39' - 1.77')
Tapping	Ø	10mm - 45mm (0.39' - 1.77')
Flange Facing and Seeger Circlips	Ø	Optional with FK (Facing Kit)
External Turning	Ø	Optional with KTE (Surfacing Kit)

ADVANTAGES

- Patented DUAL SYSTEM:** Two modules for independent task (welding and facing)
- Double motorization:** Total control of rotation and feed
- Motor protection (MMPS):** MAUCOTOOLS Motor Protection System (MMPS)
- Modular system:** Compatible with all Optional Kits to increase machining diameter up to 600mm
- Cost-effective:** No need to purchase a new machine, optimizing your investment
- Time and money savings:** One setups, quick centering kit with magnetic system
- Robust and precise:** Ø16mm tool holder, connecting tool holder bars (Ø20, Ø40mm and Ø60mm)
- Safety:** MAUCOTOOLS Error Detection System (MeDS) and MMPS
- Advanced features:** Synchronized rotation and feed, unlimited longitudinal stroke, fast electronic feed

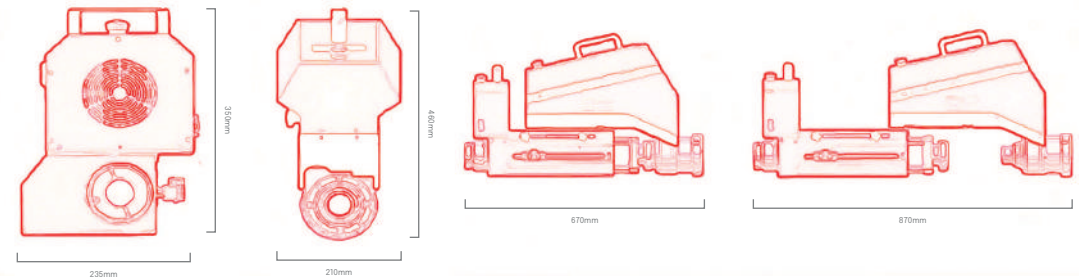

DUAL SYSTEM Feed Module

Brushless motor	YES
Phases	1
Motor type	DC
Power	125W
Speed	0-300 RPM
Feed	Electromechanical (Automatic and Manual)
MeDS	YES
MMPS	YES

DUAL SYSTEM Rotation Module

2 types of motors	Electric with 2 speeds	Hydraulic
Speed	Speed I: 54-126 RPM Speed II: 180-423 RPM	Min. 9 RPM Max. 423 RPM
Power	1800W - 220V-230V (110V Available)	5.5kW

MAUCOTOOLS S.R.L

Località Serramonda | Z.I. | 88044 | Marcellinara (CZ) | Italy
+39 0961 021836 | maucotools@maucotools.com

STANDARD PACK

LBM600 DUAL SYSTEM



 x1 cod. RT DUAL SYSTEM Rotation Module	 x1 cod. AV DUAL SYSTEM Feed Module	 x1 cod. CAV Control Panel for Feed Module	 x1 cod. CAV1 Connection cable for Feed Module	 x2 cod. C37 Power supply cable	 x2 cod. B27 Boring bar ø40mm (1.57") L=1000mm (39.37")	 x1 cod. B2760 Boring bar ø60mm (2.36") L=1000mm (39.37")	 x2 cod. B27G Internal Boring bar Coupling
 x1 cod. ECM Morse Taper Ejecting Drift	 x1 cod. CM1 Morse Cone Adapter for drilling	 x1 cod. B16 MAUCOTOOLS Locking System (MLS)	 x1 cod. A32 Bearing Carrier for Feed Module	 x4 cod. S34 Universal Support	 x1 cod. C10 Special Wrench for Universal Support	 x12 cod. S34S-60 Bracket with Spacer for Support L=60mm (2.36")	 x12 cod. SS100 Bracket for Universal support L=100mm (3.94")
 x12 cod. SS180 Bracket for Universal support L=180mm (7.08")	 x12 cod. SS250 Bracket for Universal support L=250mm (9.84")	 x1 cod. S34F Flange for Support for Boring Bar ø40mm (1.57")	 x1 cod. SP600 Flange for Support for Boring Bar ø60mm (2.36")	 x1 cod. CN600 Centering Kit from ø400mm (15.74") to ø600mm (23.62")	 x2 cod. SM30 Magnetic Fast-Centering kit	 x1 cod. C29 Special Caliper for Internal Diameter Measurement	 x1 cod. C31M Dial Gauge with Magnetic Holder
 x1 cod. P14A Toolholder ø16mm (0.63") L=40mm (1.57")	 x1 cod. P14B Toolholder ø16mm (0.63") L=60mm (2.36")	 x1 cod. P14C Toolholder ø16mm (0.63") L=100mm (3.94")	 x10 cod. P15 Carbide Insert for Toolholder	 x10 cod. P15A Torx Screw for Toolholder	 x1 cod. PC14 Torx Wrench for Toolholder	 x1 cod. GR4 Cutting Depth Adjustment Hook	 x1 cod. PC15 Toolholder Extension ø90mm (3.54")
 x1 cod. PUC250 Toolholder Extension L=140mm (5.51")	 x1 cod. PUL400 Toolholder Extension L=320mm (12.59")	 x1 cod. P14R6C Toolholder Extension 140mm (5.51")	 x1 cod. P14R6L Toolholder Extension L=210mm (8.26")	 x1 cod. S34S60 Tool Holding Fixture for LBM600			
 x1 cod. T17 Telescopic Welding Torch Shaft L=1700mm EUR Cable	 x1 cod. R17AS Front Articulated Joint for Welding Torch Shaft	 x1 cod. R17 Torch Head for Internal Welding	 x1 cod. R17AR Adaptor for R17	 x1 cod. R17P40 Torch Head Extension L=40mm (1.57")	 x1 cod. R17P60 Torch Head Extension L=60mm (2.36")	 x2 cod. R17P100 Torch Head Extension L=100mm (3.94")	 x1 cod. R17PS External Torch Head Extension L=320mm (12.59")
 x3 cod. G08C Short Welding Wire Tip ø0,8mm (0.031")	 x3 cod. G08L Long Welding Wire Tip ø0,8mm (0.031")	 x3 cod. G10C Long Welding Wire Tip ø1,0mm (0.039")	 x3 cod. G10L Long Welding Wire Tip ø1,0mm (0.039")	 x2 cod. G22C Short Gas Nozzle	 x2 cod. G22L Long Gas Nozzle	 x1 cod. C11 Complete Kit of Service Keys and Wrenches	 x1 cod. C11 Red Metal Box (Packing)

MAUCOTOOLS S.R.L

Località Serramonda | Z.I. | 88044 | Marcellinara (CZ) |
Italy +39 0961 021836 | maucotools@maucotools.com

An aerial photograph of a construction site, heavily overlaid with a semi-transparent red color. The image is framed by several white, angular lines that create a geometric, abstract pattern. The construction site below shows various structures, including what appears to be a large, rectangular structure with a grid-like pattern, possibly a ventilation system or a large window. The overall aesthetic is industrial and modern.

DUAL SYSTEM

**SMART ON-SITE
SOLUTIONS**

LBM600X

DUAL SYSTEM

Achieve high precision machining with our accurate line boring services, covering a diameter range from **Ø62mm to Ø600mm**, which can be expanded with optional kits.

Dual System Flexibility: **Independent rotation and feed modules** for simultaneous operations.



Strong and Portable: Each module weighs about 25kg, ensuring a lightweight design for effortless on-site installation.

An all-in-one solution that encompasses **Line Boring, bore welding, facing, drilling, and tapping** for multi-functional capabilities.



PORTABLE LINE BORING MACHINE LBM600X DUAL SYSTEM

WORKING AND OPERATING RANGES

Boring Bar	∅	60mm (2.36')
Internal line boring	∅	62mm - 600mm (2.44' - 23.65')
Internal Automatic Bore Welding	∅	32mm - 600mm (1.28' - 23.65')
External Automatic Bore Welding	∅	22mm - 600mm (0.88' - 23.65')
Drilling	∅	10mm - 45mm (0.39' - 1.77')
Tapping	∅	10mm - 45mm (0.39' - 1.77')
Flange Facing and Seeger Circlips	∅	Optional with FK (Facing Kit)
External Turning	∅	Optional with KTE (Surfacing Kit)

ADVANTAGES

- Patented DUAL SYSTEM:** Two modules for independent task (welding and facing)
- Stronger motor:** The machine features a more powerful 2300W motor with 4 speeds and is also available in 110V and Hydraulic versions
- Double motorization:** Total control of rotation and feed
- Motor protection (MMPS):** MAUCOTOOLS Motor Protection System (MMPS)
- Modular system:** Compatible with all Optional Kits to reduce and increasing machining diameter starting from 22mm up to 1200mm
- Cost-effective:** No need to purchase a new machine, optimizing your investment
- Time and money savings:** One setup, many working operations
- Robust and precise:** ∅16mm tool holder, connecting tool holder bars (∅20, ∅40mm and ∅60mm)
- Safety:** MAUCOTOOLS Error Detection System (MeDS) and MMPS
- Advanced features:** Synchronized rotation and feed, unlimited longitudinal stroke, fast electronic feed

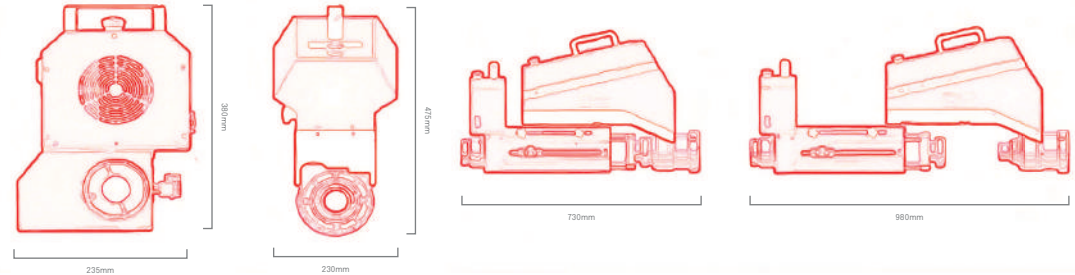

DUAL SYSTEM Feed Module

Brushless motor	YES
Phases	1
Motor type	DC
Power	125W
Speed	0-300 RPM
Feed	Electromechanical (Automatic and Manual)
MeDS	YES
MMPS	YES

DUAL SYSTEM Rotation Module

2 types of motors	Electric with 4 speeds	Hydraulic
Speed	Speed I: 30-90 RPM Speed II: 50-140 RPM Speed III: 130-400 RPM Speed IV: 210-630 RPM	Min. 9 RPM Max. 423 RPM
Power	2300W - 220V-230V (110V Available)	5.5kW

MAUCOTOOLS S.R.L

Località Serramonda | Z.I. | 88044 | Marcellinara (CZ) | Italy
+39 0961 021836 | maucotools@maucotools.com

STANDARD PACK

LBM600X DUAL SYSTEM



 RT60 DUAL SYSTEM Rotation Module	 AV DUAL SYSTEM Feed Module	 CAV Control Panel for Feed Module	 CAV1 Connection cable for Feed Module	 C37 Power supply cable	 B2760X Boring bar ø60mm (2.36") L=1000mm (39.37")	 B27GX Internal Boring bar Coupling	 ECM Morse Taper Ejecting Drift
 CM1 Morse Cone Adapter for drilling	 A3260 Bearing Carrier for Feed Module	 S3460 Universal Support	 C10X Special Wrench for Universal Support	 S34S-60 Bracket with Spacer for Support L=60mm (2.36")	 SS100 Bracket for Universal support L=100mm (3.94")	 SS180 Bracket for Universal support L=180mm (7.08")	 SS250 Bracket for Universal support L=250mm (9.84")
 S34F60 Flange for Support	 MCS60 Microspand up to ø600mm (23.62")	 CN600X Centering Kit from ø62mm (2.44") to ø600mm (23.62")	 C29 Special Caliper for Internal Diameter Measurement	 C31MX Dial Gauge with Magnetic Holder	 P14B Toolholder ø16mm (0.63") L=60mm (2.36")	 P14C Toolholder ø16mm (0.63") L=100mm (3.94")	 P14D Toolholder ø16mm (0.63") L=120mm (4.73")
 P15 Carbide Insert for Toolholder	 P15A Torx Screw for Toolholder	 PC14 Torx Wrench for Toolholder	 GR6 Cutting Depth Adjustment Hook	 P14R6A Toolholder Extension L=50mm (1.97")	 P14R6B Toolholder Extension L=100mm (3.94")	 P14R6C Toolholder Extension 140mm (5.51")	 P14R6L Toolholder Extension L=210mm (8.26")
 S34S60 Tool Holding Fixture for LBM600	 CPS600 Counterweight for Line Boring						
 T17 Telescopic Welding Torch Shaft L=1700mm EUR Cable	 R17AS Front Articulated Joint for Welding Torch Shaft	 R17 Torch Head for Internal Welding	 R17AR Adaptor for R17	 R17P40 Torch Head Extension L=40mm (1.57")	 R17P60 Torch Head Extension L=60mm (2.36")	 R17P100 Torch Head Extension L=100mm (3.94")	 R17PS External Torch Head Extension L=320mm (12.59")
 G08C Short Welding Wire Tip ø0.8mm (0.031")	 G08L Long Welding Wire Tip ø0.8mm (0.031")	 G10C Long Welding Wire Tip ø1.0mm (0.039")	 G10L Long Welding Wire Tip ø1.0mm (0.039")	 G22C Short Gas Nozzle	 G22L Long Gas Nozzle	 RB60 Reduction bushings for Welding Torch	 C11X Complete Kit of Service Keys and Wrenches
 C11X Red Metal Box (Packing)							

MAUCOTOOLS S.R.L

Località Serramonda | Z.I. | 88044 | Marcellinara (CZ) |
Italy +39 0961 021836 | maucotools@maucotools.com





DUAL SYSTEM

OB SERIES



PORTABLE LINE BORING MACHINE OB200 DUAL SYSTEM

WORKING AND OPERATING RANGES

Boring Bar	∅	20mm - 40mm (0.78" - 1.57")
Internal line boring	∅	22mm - 200mm (0.88" - 7.87")
Internal Automatic Bore Welding	∅	Extra Kit
External Automatic Bore Welding	∅	Extra Kit
Drilling	∅	Extra Kit
Tapping	∅	Extra Kit
Flange Facing and Seeger Circlips	∅	Optional with FK (Facing Kit)
External Turning	∅	Optional with KTE (Surfacing Kit)

ADVANTAGES

Patented DUAL SYSTEM: Two modules for independent task (welding and facing)

Double motorization: Total control of rotation and feed

Motor protection (MMPS): MAUCOTOOLS Motor Protection System (MMPS)

Modular system: Compatible with all Optional Kits to increase machining diameter up to 600mm and operations (Automatic Bore Welding, Facing, Drilling and Tapping).

Cost-effective: No need to purchase a new machine, optimizing your investment

Time and money savings: One setups, quick centering kit with magnetic system

Robust and precise: ∅16mm tool holder, connecting tool holder bars (∅20, ∅40mm and ∅60mm)

Safety: MAUCOTOOLS Error Detection System (MeDS) and MMPS

Advanced features: Synchronized rotation and feed, unlimited longitudinal stroke, fast electronic feed

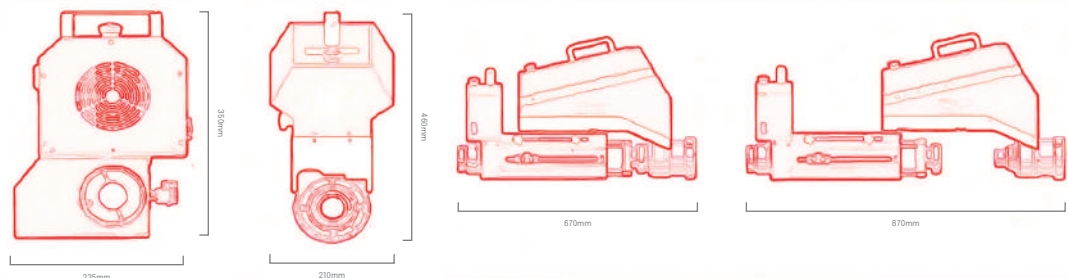

DUAL SYSTEM Feed Module

Brushless motor	YES
Phases	1
Motor type	DC
Power	125W
Speed	0-300 RPM
Feed	Electromechanical (Automatic and Manual)
MeDS	YES
MMPS	YES

DUAL SYSTEM Rotation Module

2 types of motors	Electric with 2 speeds	Hydraulic
Speed	Speed I: 54-126 RPM Speed II: 180-423 RPM	Min. 9 RPM Max. 423 RPM
Power	1800W - 220V-230V (110V Available)	5.5kW

MAUCOTOOLS S.R.L

Località Serramonda | Z.I. | 88044 | Marcellinara (CZ) | Italy
+39 0961 021836 | maucotools@maucotools.com

STANDARD PACK

OB200 DUAL SYSTEM



MAUCOTOOLS S.R.L

Località Serramonda | Z.I. | 88044 | Marcellinara (CZ) |
Italy +39 0961 021836 | maucotools@maucotools.com



PORTABLE LINE BORING MACHINE OB400 DUAL SYSTEM

WORKING AND OPERATING RANGES

Boring Bar	∅	40mm (1.57")
Internal line boring	∅	42mm - 400mm (1.65" - 15.74")
Internal Automatic Bore Welding	∅	Extra Kit
External Automatic Bore Welding	∅	Extra Kit
Drilling	∅	Extra Kit
Tapping	∅	Extra Kit
Flange Facing and Seeger Circlips	∅	Optional with FK (Facing Kit)
External Turning	∅	Optional with KTE (Surfacing Kit)

ADVANTAGES

- Patented DUAL SYSTEM:** Two modules for independent task (welding and facing)
- Double motorization:** Total control of rotation and feed
- Motor protection (MMPS):** MAUCOTOOLS Motor Protection System (MMPS)
- Modular system:** Compatible with all Optional Kits to increase machining diameter up to 600mm and operations (Automatic Bore Welding, Facing, Drilling and Tapping).
- Cost-effective:** No need to purchase a new machine, optimizing your investment
- Time and money savings:** One setups, quick centering kit with magnetic system
- Robust and precise:** ∅16mm tool holder, connecting tool holder bars (∅20, ∅40mm and ∅60mm)
- Safety:** MAUCOTOOLS Error Detection System (MeDS) and MMPS
- Advanced features:** Synchronized rotation and feed, unlimited longitudinal stroke, fast electronic feed

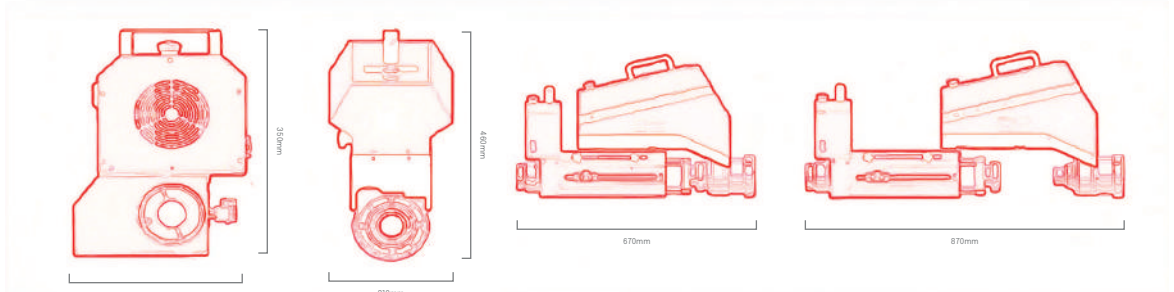

DUAL SYSTEM Feed Module

Brushless motor	YES
Phases	1
Motor type	DC
Power	125W
Speed	0-300 RPM
Feed	Electromechanical (Automatic and Manual)
MeDS	YES
MMPS	YES

DUAL SYSTEM Rotation Module

2 types of motors	Electric with 2 speeds	Hydraulic
Speed	Speed I: 54-126 RPM Speed II: 180-423 RPM	Min. 9 RPM Max. 423 RPM
Power	1800W - 220V-230V (110V Available)	5.5kW

MAUCOTOOLS S.R.L

Località Serramonda | Z.I. | 88044 | Marcellinara (CZ) | Italy
+39 0961 021836 | maucotools@maucotools.com

STANDARD PACK

OB400 DUAL SYSTEM



MAUCOTOOLS S.R.L

Località Serramonda | Z.I. | 88044 | Marcellinara (CZ) |
Italy +39 0961 021836 | maucotools@maucotools.com



LEM 250
DUAL SYSTEM

MAUCOTOOLS

LEM 250
DUAL SYSTEM

DUAL SYSTEM

MAUCOTOOLS

0 1 2 3 4 5 6 7 8 9 10 11 12 13 14 15 16 17 18 19 20
20 19 18 17 16 15 14 13 12 11 10 9 8 7 6 5 4 3 2 1 0

MAUCOTOOLS

L3M

DUAL SYSTEM

START SERIES



PORTABLE LINE BORING MACHINE **START 160 DUAL SYSTEM**

WORKING AND OPERATING RANGES

Boring Bar	∅	20mm - 40mm (0.78" - 1.57")
Internal line boring	∅	22mm - 160mm (0.88" - 6.30")
Internal Automatic Bore Welding	∅	Extra Kit
External Automatic Bore Welding	∅	Extra Kit
Drilling	∅	Extra Kit
Tapping	∅	Extra Kit
Flange Facing and Seeger Circlips	∅	Optional with FK (Facing Kit)
External Turning	∅	Optional with KTE (Surfacing Kit)

ADVANTAGES

Patented DUAL SYSTEM: Two independent modules that can be mounted on the same side or, when space is limited, on opposite sides of the bore. Their separate design also allows for weight distribution, making the machine truly portable.

One Motor and Automatic Feed: Ensures simplified operation with synchronized control, providing consistent performance and reduced setup time.

Modular system: The START model offers a flexible solution that allows you to begin with essential capabilities and expand as your needs grow. By adding optional kits, you can increase the machining diameter up to 600mm and enhance functionality with additional operations such as welding, drilling, tapping, facing, and external turning. This scalable approach ensures you invest only in what you need, when you need it.

Cost-effective and Competitive Price: No need to purchase a new machine, optimizing your investment.

Time and money savings: One setups, quick centering kit with magnetic system

Robust and precise: ∅16mm tool holder, connecting tool holder bars (∅20, ∅40mm and ∅60mm).

Advanced features: Synchronized rotation and feed, unlimited longitudinal stroke.

DUAL SYSTEM START Feed Module

Feed type	Mechanical
Screw Transmission	Automatic and Manual
Stroke	200mm (longer on request)

DUAL SYSTEM Rotation Module

2 types of motors	Electric with 2 speeds	Hydraulic
Speed	Speed I: 54-126 RPM Speed II: 180-423 RPM	Min. 9 RPM Max. 423 RPM
Power	1800W - 220V-230V (110V Available)	5.5kW

START DUAL SYSTEM

Your Entry-level model... but Made in Italy

MAUCOTOOLS S.R.L

Località Serramonda | Z.I. | 88044 | Marcellinara (CZ) | Italy
+39 0961 021836 | maucotools@maucotools.com

STANDARD PACK

START160 DUAL SYSTEM





PORTABLE LINE BORING MACHINE **START400 DUAL SYSTEM**

WORKING AND OPERATING RANGES

Boring Bar	∅	40mm (1.57')
Internal line boring	∅	42mm - 400mm (1.65' - 15.75')
Internal Automatic Bore Welding	∅	Extra Kit
External Automatic Bore Welding	∅	Extra Kit
Drilling	∅	Extra Kit
Tapping	∅	Extra Kit
Flange Facing and Seeger Circlips	∅	Optional with FK (Facing Kit)
External Turning	∅	Optional with KTE (Surfacing Kit)

ADVANTAGES

Patented DUAL SYSTEM: Two independent modules that can be mounted on the same side or, when space is limited, on opposite sides of the bore. Their separate design also allows for weight distribution, making the machine truly portable.

One Motor and Automatic Feed: Ensures simplified operation with synchronized control, providing consistent performance and reduced setup time.

Modular system: The START model offers a flexible solution that allows you to begin with essential capabilities and expand as your needs grow. By adding optional kits, you can increase the machining diameter up to 600mm and enhance functionality with additional operations such as welding, drilling, tapping, facing, and external turning. This scalable approach ensures you invest only in what you need, when you need it.

Cost-effective and Competitive Price: No need to purchase a new machine, optimizing your investment.

Time and money savings: One setups, quick centering kit with magnetic system

Robust and precise: ∅16mm tool holder, connecting tool holder bars (∅20, ∅40mm and ∅60mm).

Advanced features: Synchronized rotation and feed, unlimited longitudinal stroke.

DUAL SYSTEM START Feed Module

Feed type	Mechanical
Screw Transmission	Automatic and Manual
Stroke	200mm (longer on request)

DUAL SYSTEM Rotation Module

2 types of motors	Electric with 2 speeds	Hydraulic
Speed	Speed I: 54-126 RPM Speed II: 180-423 RPM	Min. 9 RPM Max. 423 RPM
Power	1800W - 220V-230V (110V Available)	5.5kW

START DUAL SYSTEM

Your Entry-level model... but Made in Italy

MAUCOTOOLS S.R.L

Località Serramonda | Z.I. | 88044 | Marcellinara (CZ) | Italy
+39 0961 021836 | maucotools@maucotools.com

STANDARD PACK

START400 DUAL SYSTEM



MAUCOTOOLS S.R.L

Località Serramonda | Z.I. | 88044 | Marcellinara (CZ) |
Italy +39 0961 021836 | maucotools@maucotools.com



DUAL SYSTEM

EXTRA KITS

EXTRA KITS FOR LINE BORING MACHINES

REDUCING/INCREASING

LBM250 DUAL SYSTEM

Extra Kit K400	250mm - 400mm (9.84' - 15.75')
Extra Kit K600B	250mm - 600mm (9.84' - 23.65')
Extra Kit KB30	starting from 32mm (1.26')
Extra Kit KB50	starting from 52mm (2.05')

LBM400 DUAL SYSTEM

Extra Kit K600	400mm - 600mm (15.75' - 23.65')
Extra Kit K600B	250mm - 600mm (9.84' - 23.65')
Extra Kit KB20	starting from 22mm (0.86')
Extra Kit KB30	starting from 32mm (1.26')
Extra Kit KB50	starting from 52mm (2.05')

LBM600 DUAL SYSTEM

Extra Kit KB20	starting from 22mm (0.86')
Extra Kit KB30	starting from 32mm (1.26')
Extra Kit KB50	starting from 52mm (2.05')

LBM600X DUAL SYSTEM

Extra Kit KB20X	starting from 22mm (0.86')
------------------------	----------------------------

OB200 DUAL SYSTEM

Extra Kit KC250	from OB200 to LBM250
Extra Kit KOB400	200mm - 400mm (9.84' - 15.75')
Extra Kit KB30	starting from 32mm (1.26')
Extra Kit KB50	starting from 52mm (2.05')

OB400 DUAL SYSTEM

Extra Kit KC400	from OB400 to LBM400
Extra Kit KB20	starting from 22mm (0.86')
Extra Kit KB30	starting from 32mm (1.26')
Extra Kit KB50	starting from 52mm (2.05')

START160 DUAL SYSTEM

Extra Kit KOK250	from START160 to LBM250
Extra Kit KK400	160mm - 400mm (6.30' - 15.75')
Extra Kit KB30	starting from 32mm (1.26')
Extra Kit KB50	starting from 52mm (2.05')

START400 DUAL SYSTEM

Extra Kit KOK400	from START400 to LBM400
Extra Kit KB20	starting from 22mm (0.86')
Extra Kit KB30	starting from 32mm (1.26')
Extra Kit KB50	starting from 52mm (2.05')



MAUCOTOOLS S.R.L

Località Serramonda | Z.I. | 88044 | Marcellinara (CZ) |
Italy +39 0961 021836 | maucotools@maucotools.com

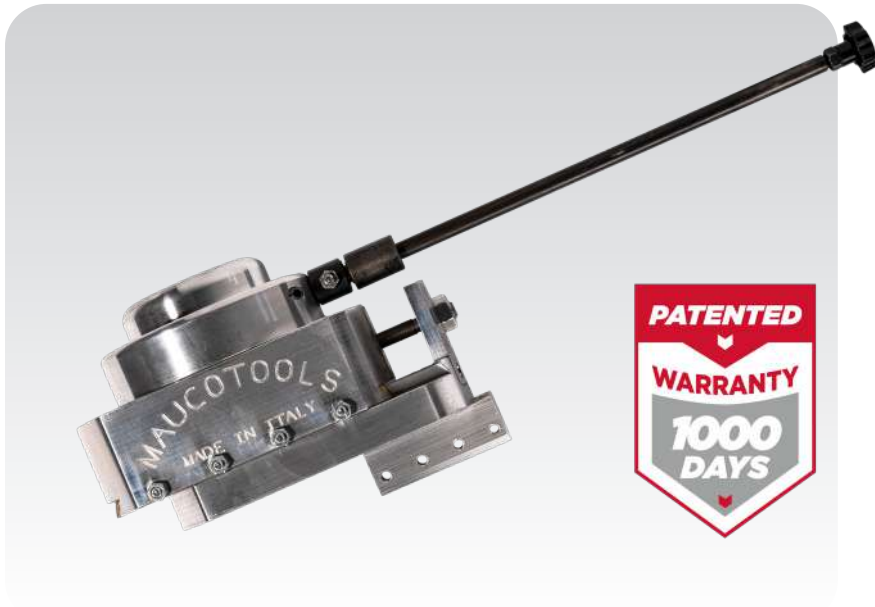

FK SERIES

FACING KIT FK

The MAUCOTOOLS Facing Kit FK for Portable Line Boring Machines is a combination of power and versatility for **FLANGE FACING**, creation of **SEEGER-CIRCLIPS GROOVES** and **EXTERNAL MACHINING** (External cylindrical turning) of PINS and AXLES.

The FK Series in combination with MAUCOTOOLS Portable Line Boring Machines DUAL SYSTEM offers the opportunity to **make independent operations, saving time and money**: FLANGE FACING + AUTOMATIC BORE WELDING.

ADVANTAGES

Lightweight body: The die-cast aluminium body allows continuous operations in the toughest conditions.

Robust design: Its robust construction ensures vibration-free performance.

Complete control: The operating handle activates and deactivates the cutting motion of the facing kit remotely and safely. The end-of-stroke switch allows you to set the cutting surface.

Safe: When the end-of-stroke is reached, a special device comes into action that stops the cutting motion even if the facing kit continues to turn.

TECHNICAL SPECIFICATIONS	FK250	FK400	FK600
Boring Bar diameter	40mm (1.57")	40mm (1.57")	40mm (1.57")
Min. Facing diameter	45mm (1.77")	45mm (1.77")	45mm (1.77")
Max. Facing diameter	250mm (9.84")	400mm (15.74")	600mm (23.62")
Seeger-Circlip Grooves Creation	Optional with FKSS Kit	Optional with FKSS Kit	Optional with FKSS Kit
External Turning	Optional with Extra Kit	Optional with Extra Kit	Optional with Extra Kit
Weight	17 Kg	17,5 Kg	18,6 Kg
Composed of	N.1 Facing Head N.1 Activation Lever N.6 Brackets L=180mm N.6 Spacers L=210mm N.1 Tool Holder Slide N.1 Tool Holder Ø10mm N.1 Set Service Wrenches	N.1 Facing Head N.1 Activation Lever N.6 Brackets L=180mm N.6 Spacers L=210mm N.2 Tool Holder Slide N.1 Tool Holder Ø10mm N.1 Set Service Wrenches	N.1 Facing Head N.1 Activation Lever N.6 Brackets L=180mm N.6 Brackets L=250mm N.6 Spacers L=210mm N.3 Tool Holder Slide N.1 Tool Holder Ø10mm N.1 Set Service Wrenches

Compatibility

All MAUCOTOOLS Portable Line Boring machines
For other brands, please contact us for more information

Facing head with operating handle



Adjustable End-of-stroke



MAUCOTOOLS S.R.L

Località Serramonda | Z.I. | 88044 | Marcellinara (CZ) | Italy
+39 0961 021836 | maucotools@maucotools.com



MAUCOTOOLS
MADE IN ITALY



EXTRA KIT

SMART DRILLING SDM

Thanks to the **SDM KIT (SMART DRILLING MAUCOTOOLS)**, your **DUAL SYSTEM** Portable Boring Machine evolves into a powerful and versatile **Portable Vertical Drilling Machine** with speed, precision, and ease.

This innovative attachment expands the capabilities of your **DUAL SYSTEM**, enabling efficient and accurate vertical drilling operations directly on-site. Whether you're handling challenging repair tasks or tackling precision engineering projects, the **SDM KIT** offers unparalleled flexibility and performance.

ADVANTAGES

- Quick Transformation:** Seamlessly converts your **DUAL SYSTEM** into a vertical drilling powerhouse in just a few steps.
- Enhanced Precision:** Designed for flawless vertical drilling with perfect alignment, ensuring superior results every time.
- Robust & Portable:** Maintains the portability and strength of the **DUAL SYSTEM**, allowing you to work in any environment without compromising quality.
- Magnetic Base:** Features a strong magnetic base that securely attaches to the workpiece without the need to weld any support structure, saving time and effort.
- Multi-Functionality:** Ideal for applications requiring both line boring and vertical drilling, reducing the need for multiple machines.

TECHNICAL SPECIFICATIONS

Boring Bar diameter	40mm (1.57")
Max. Drilling and Tapping diameter	45mm (1.77")
Max. Counterboring diameter	150mm (5.90")
Totale Gross Weight	43 Kg
Composed of	Auto Centering Mandrel 1/13 Cone Morse Prolong 3/3 Conical Attachment for Mandrel B16/3 Reduction socket CM3/2 Electromagnetic Support (Electric) Electromagnetic Support Adapter Portable Boring Machine Drilling Setup
Compatibility	All MAUCOTOOLS Portable Line Boring machines

MAUCOTOOLS S.R.L

Località Serramonda | Z.I. | 88044 | Marcellinara (CZ) | Italy
+39 0961 021836 | maucotools@maucotools.com



HYDRAULIC POWER PACK

HHP SERIES

MAUCOTOOLS Hydraulic Power Pack for Portable Line Boring Machines, HPP Series, embodies a fusion of strength and efficiency for HYDRAULIC POWER SUPPLY operations.

The Hydraulic Power Pack is designed to deliver a steady and robust flow, essential for demanding boring operations, and supports precision boring under various working conditions. Its versatility makes it ideal for a wide range of industrial applications and field maintenance tasks.

ADVANTAGES

- High Performance:** Provides a steady and robust hydraulic flow essential for demanding boring operations, ensuring consistent power and efficiency.
- Precision Support:** Designed to support precision boring under various working conditions, enhancing the accuracy and quality of your work.
- Versatility:** Ideal for a wide range of industrial applications and field maintenance tasks, making it a versatile addition to your equipment.
- Compatibility:** Specifically designed for use with MAUCOTOOLS Portable Line Boring Machines, particularly the DUAL SYSTEM series.
- Robust Design:** Built to withstand the rigors of demanding operational environments, ensuring durability and reliability.
- Efficiency:** Optimizes hydraulic power supply operations, reducing operational costs and improving overall productivity.
- Ease of Use:** User-friendly controls, making it easy to operate even for less experienced users.

TECHNICAL SPECIFICATIONS	HHP-M (Manual)	HHP-A (Semi-automatic)
Pump	11,2cc (15,7 lt)	11,2cc (15,7 lt)
Pressure max.	180bar	180bar
Motor	5,5kW 3-Phase, 4 poles	5,5kW 3-Phase, 4 poles
Tank	55 lt	75 lt
Suction Filter	90 micron	90 micron
Exhaust Filter	60 micron	60 micron
Dimensions	Length: 600mm Height: 858mm (HPP-A: 930mm) Depth: 490mm	

MAUCOTOOLS S.R.L



Località Serramonda | Z.I. | 88044 | Marcellinara (CZ) | Italy
 +39 0961 021836 | maucotools@maucotools.com



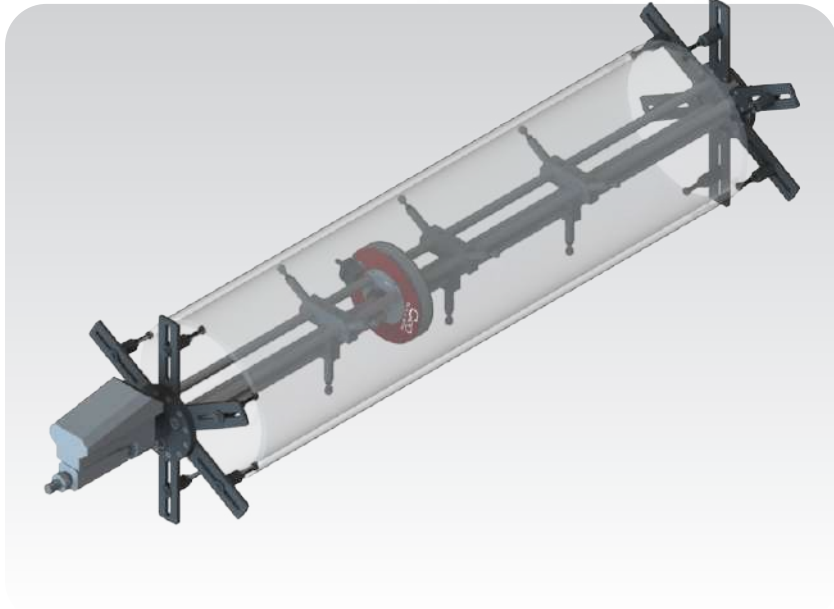

KGD SERIES

KIT FOR BIG DIAMETERS

The MAUCOTOOLS KGD System is an innovative, patented solution designed to significantly increase the working range of the majority of portable line boring machine on the market, including MAUCOTOOLS' DUAL SYSTEM. With the KGD System, you can achieve precision machining on diameters ranging from 400mm to 2000mm (15.75" to 78.74").

The MAUCOTOOLS KGD System offers unmatched precision and robustness. The tool holder mechanism reduces overhang, enabling smoother, faster, and more accurate machining. The use of three parallel support bars ensures the stability of the entire mechanism, even under demanding conditions.

UNIQUE FEATURES & ADVANTAGES

High Precision & Stability: The KGD System minimizes radial length between the motor shaft axis and the workpiece, reducing tool deflection and increasing accuracy. The mechanism is supported by three drive shafts instead of the traditional single shaft, ensuring unparalleled rigidity and stability during operation.

Multi-Functionality: Enables a wide range of operations, including internal boring over long distances, external turning, and facing, even simultaneously, thanks to the patented design.

Universal Compatibility: The system is compatible with most portable line boring machines on the market. For machines with unique specifications, MAUCOTOOLS can provide customized adapters to ensure seamless integration.

Customizable Internal Supports: For operations requiring extreme working lengths, internal supports can be added (available upon request), further enhancing stability and precision.

TECHNICAL SPECIFICATIONS	KGD800	KGD1200	KGD1600	KGD2000
Line Boring diameter	400-800mm	800-1200mm	1200-1600mm	1600-2000mm
External Machining diameter	Optional	Optional	Optional	Optional
Flange Facing diameter	Optional	Optional	Optional	Optional
Key components				
Tool Holder Mechanism: Transmits rotation and feed motion from the portable line boring machine to the cutting tool.				
Main Supports: Provide robust centering and secure attachment for the mechanism.				
Drive Shafts: Positioned parallel to the motor shaft, these ensure rigidity and strength, delivering exceptional accuracy.				
Motor Shaft: Seamlessly connects with the line boring machine to power the operation.				

Compatibility

All MAUCOTOOLS Portable Line Boring machines
For other brands, please contact us for more information

MAUCOTOOLS S.R.L



Località Serramonda | Z.I. | 88044 | Marcellinara (CZ) | Italy
+39 0961 021836 | maucotools@maucotools.com

Discover more on:
www.maucotools.com

MAUCOTOOLS S.R.L.

Località Serramonda | Z.I. | 88044 | Marcellinara (CZ) |
Italy | +39 0961 021836 | maucotools@maucotools.com